

EDUCATOR GUIDE



MacGillivray Freeman's

AMERICA'S MUSICAL JOURNEY

A story of culture, creativity and the music that shaped America.



TABLE OF CONTENTS

INTRODUCTION TO GUIDE	3
BACKGROUND TO MUSIC	4
<hr/>	
LESSON 1: INSTRUMENTS (K-1)	7
LESSON 2: WANTS AND NEEDS (K-1)	18
LESSON 3: COMMUNITIES (2-3).....	28
LESSON 4: CULTURE (2-3).....	39
LESSON 5: ELLIS ISLAND (4-5).....	50
LESSON 6: THE GREAT MIGRATION (4-5).....	59
LESSON 7: CULTURAL PROJECT (6-8).....	67
LESSON 8: LYRICAL TALES (6-8).....	74
SCIENCE EXTENSION LESSON: STRING TELEPHONE (K-2)	84
SCIENCE EXTENSION LESSON: ENCODING SOUND (3-5)	89
<hr/>	
ADDITIONAL RESOURCES.....	93
ACKNOWLEDGMENTS	94



INTRODUCTION TO GUIDE:

The *America's Musical Journey* Educator Guide, created by Discovery Place Education Studio in Charlotte, North Carolina, in partnership with MacGillivray Freeman Films and Brand USA, is appropriate for students in the primary grades (K–8). The guide is most useful when used as a companion to the film, but also valuable as a resource on its own. Teachers are strongly encouraged to adapt activities included in this guide to support specific state or national standards and the needs of their students. Activities developed for this guide support national Common Core ELA standards and C3 social studies standards. This guide focuses on the significant historic and cultural movements in American music highlighted by the film, but educators will find that *America's Musical Journey* features many other content areas such as language arts, geography, math, and fine arts. All lesson plans and activities are designed in the STEM learning style. Lessons challenge students to learn through experiential modeling, investigating claims, forming theories, and testing ideas. In addition to eight ELA and Social Studies lessons, two Science Extension lessons are included in the guide. These lessons help guide teachers to connect *America's Musical Journey* to math and the science of sound. At the end of the guide, teachers can find additional resources to assist with cross-curricular planning.

Today and throughout the history of the United States, major waves of immigration play an integral part in shaping American culture. These waves keep the United States demographically young, enriched in a diverse culture, and frequently add new ideas that enhance America's influence in the world. One of the most significant movements in American history shaped by immigration and the merging of numerous cultures is music. In a land with compelling diversity, music has always brought people together. *America's Musical Journey* tells the fascinating story of how this collision of cultures sparked unique creative changes in our musical tapestry from Louis Armstrong's improvisational jazz to the Rock and Roll cultural revolution inspired by Elvis.

America's Musical Journey is a MacGillivray Freeman film for IMAX® and giant screen theatres produced in association with Brand USA and presented globally by Expedia, Inc.. *America's Musical Journey* is directed by Academy Award®-nominated filmmaker Greg MacGillivray and produced by Shaun MacGillivray. The film has a run time of 40 minutes.



BACKGROUND:

CULTURAL DIVERSITY

America has always been known as the “land of immigrants.” For hundreds of years, people from around the world migrated to these lands in search of new opportunities. With them they brought new languages, cultures, and song. The first major wave of immigration took place during the colonial era. Many communities established at this time were influenced by European culture.

As these communities grew, the African slave trade became a significant factor in the growing of colonial economies. Between the seventeenth and nineteenth centuries, approximately ten to twelve million enslaved West Africans were brought to the New World, with more than half a million brought directly to the southern ports of Louisiana. Traveling from Africa in malevolent conditions, new arrivals were sold and dispatched quickly to their new owner’s small farm, plantation, or urban workshop, where they would make up the heart of the workforce of colonial America. To cope with their disrupted lives, the uprooted Africans used memories of their musical traditions and found solace in song, instruments, and dance.

THE BIRTH OF THE BLUES

By the nineteenth century, the American South led the country in cotton production. African slaves were forced to work in harsh conditions out in the fields to keep up with the economic demands. Slaves often voiced their personal experiences with this unrelenting reality through work songs. These songs, often described as loose narratives, expressed the loss of their loved ones and the cruelty of white folk. The special notes in their work songs sounded “bent” or “worried” and became the basis of a new form of music called the Blues. The Blues not only helped alleviate the loneliness and isolation felt by the slaves, but it helped slaves to communicate with one another and lift spirits.

As time progressed, the Blues combined unique vocal techniques that were a blend of African and American styles. Singers used grunts, groans, and screams in their music to express emotion and frequently shortened or lengthened words to fit the rhythm of their music. Singers also created blue notes, which were tones from the African vocal scale that fell outside the traditional European musical scale. The guitar and harmonica were able to replicate these blue notes better than the piano, banjo, and fiddle. As a result, the guitar and harmonica became the staple instruments in blues music and in African American music in the late nineteenth century.



BACKGROUND CONTINUED:

THE BIRTH OF JAZZ

The Blues have had a strong influence on virtually all American popular music, including jazz. The first popular style of jazz emerged from New Orleans around 1900. At the time, New Orleans was an individualistic city with relative racial tolerance and wide musical influences from many cultures, such as African, Caribbean islands, and Creole. Early pioneers of New Orleans jazz included Jelly Roll Morton, Buddy Bolden, and Louis Armstrong.

Louis Armstrong first made a name for himself as early as 14 years of age playing in the neighborhood clubs of New Orleans. He further refined his abilities while playing on a Mississippi Riverboat during three summers. But it was when he joined The Great Migration to Chicago with one million other African Americans fleeing the Jim Crow laws of the South in 1922 that his jazz music started to change the nation and cross the segregated color lines. Louis was the first great jazz soloist with his amazing ability to improvise stunning melodies. His originality and charisma were considerably responsible for the growing popularity of jazz across cities, such as New Orleans, Chicago and New York. As this popular form of music spread from city to city, jazz began to take on new forms influenced by each city's blend of cultures, such as Hot Jazz, Swing and Afro-Cuban Jazz.

“What we play is life.” --- Louis Armstrong

THE LATIN TINGE

Many rhythmic beats of samba, rumba, mambo, tango, and salsa have had a major impact on popular music, and their strongest influences were felt in jazz music. This influence became known as the “Latin Tinge.” This “tinge” largely contributed to dance fads as well from the 1930s through the 1950s.

While the Latin Tinge influenced countless musicians for decades, Latin performers have spiced up tinge in the twenty-first century by incorporating European electronica dance music, Jamaican reggae, African soukous, and American hip-hop. Though Latin music continues to evolve, it continues to preserve elements of the past, particularly its strong roots in Amerindian and African cultures.



BACKGROUND CONTINUED:

COUNTRY MUSIC ROOTS

As the country continued to industrialize in the early 1900s, many Appalachian people left the Great Smoky Mountains to work in factories in Georgia and Tennessee. With them, they brought their signature “hillbilly music”, which was derived from music brought to the southern mountains of Appalachia by displaced fiddle-wielding Scots and Irish in the 18th and 19th centuries and combined with the musical influences of enslaved West Africans whose “banjar” was a precursor to the banjo. Music centers like Atlanta began branding this new style and recording it for distribution around the country. The rise of radio broadcasting as entertainment led to stations hosting a barn dance country music show. The most famous of these shows, the Grand Ole Opry, first aired from a Nashville radio station in 1925 and continues to play this very day. Today, country music still remains one of the most popular styles of music with various subgenres including folk, bluegrass, and country pop.

THE BIRTH OF ROCK AND ROLL

As freed slaves moved across the country to start new lives, West African traditions collided with the European musical traditions. Borrowing from the African American-influenced musical styles of rhythm and blues, jazz, and country, rock and roll developed its signature sound. Songs boldly featured electric guitar riffs with defined beats and shouted lyrics. Rock and roll attracted large personalities to its genre and music shows developed a theatrical nature. But was the barrage of recordings made from 1954 to 1958 by Elvis Presley that ignited the spark for a musical, cultural and social revolution that shook the world. Elvis, forever known as the King of Rock and Roll, grew up singing in gospel choirs and his music, much as Louis Armstrong’s jazz was doing, helped facilitate a new acceptance and appreciation of black culture. Today, his music and style continue to inspire artists of all kinds of innovate and break down barriers.

ONE OF A KIND

American music reflects the rich cultural diversity of the American people. From blues to jazz to hip hop, America has contributed a rich legacy of musical styles to the world. The range, depth, and quality of popular musical styles that have developed over time are truly amazing. These styles could not have happened anywhere else in the world, for they are unique products of the mixing of cultures, geography, and technology that helped propagate each style.

LESSON 1: INSTRUMENTS

GRADE LEVEL K-1

(1) 15 MINUTE PREP LESSON

(2) 45 MINUTE LESSONS



GRADE LEVEL K-1
(1) 15 MINUTE PREP LESSON
(2) 45 MINUTE LESSONS

ELA STANDARDS:

- Demonstrate basic knowledge of one-to-one letter-sound correspondences by producing the primary sound or many of the most frequent sounds for each consonant.
- Know and apply grade-level phonics and word analysis skills in decoding words.

SOCIAL STUDIES STANDARDS:

- Explain why and how people, goods, and ideas move from place to place.

LESSON 1: INSTRUMENTS

LESSON OVERVIEW:

In this lesson, students learn about different kinds of instruments from around the world. These instruments traveled with individuals when they came to the United States and have become a part of our own musical culture. Students practice writing and sounding out instrument names. Afterwards, students build their own instruments to create music.

FROM THE FILM:

In *America's Musical Journey*, we see how cultures collided in New Orleans to create the lively form of jazz that Louis Armstrong was famous for. New Orleans was the only location in the New World where slaves were allowed to own drums, and they regularly congregated in Congo Square on Sundays to dance and play music. In the early 19th century, black musicians began combining their West African musical traditions with European instruments like the English horn and the trumpet, which led to a radical new form of music – jazz – that defined the city. Each culture brings with it the instruments of their homeland, and together, creates something uniquely American.



LESSON 1: INSTRUMENTS

MATERIALS:

- Teacher Handout*
- Instruments Around the World* (student sheet)
- Making My Instrument Sheet* (student sheet)
- Paper towel rolls cut in half or toilet paper rolls
- Sandwich bags
- Glue
- Blue construction paper
- Red construction paper
- Glue
- Duct Tape
- Crayons
- Optional- Brads
- Bag of rice
- Bag of beans
- Bag of plastic beads

TEACHER PREP:

DAY 1:

Print off copies of the teacher hand out or prepare them to be displayed on your overhead projector. Print off 1 copy of the *Instruments Around the World* for each student. Give each student a set of crayons (or coloring device of your choice) and pencil to write with.

DAY 2:

During this class, each student will create a shaker percussion instrument by filling a toilet paper roll with material, capping each side, decorating it, and shaking it back and forth. Before class, cut out 1-inch triangles from red construction paper and 1-inch squares from red paper. Create a baggie of triangles and a baggie of squares for each group of students. There should be about 20 squares and triangles in each bag.

For each paper roll, cap one side completely with duct tape. It is also optional to place brass brads along the roll. This will make the sound of the shaking more pronounced but is not absolutely necessary. If students have the tactile skills, they can also do this themselves.

Have a teacher table ready for students to choose what material they want to fill their instrument with (rice, beans, or beads). You can use anywhere between 1/4 to 1/2 of material to fill the tube.

TO DO:

BEFORE VIEWING THE FILM:

Prepare students to view the film, *America's Musical Journey*.

Ask students to name a memory or tradition they have with their family where they play music or sing. Ask students what instruments they may already know of that make music. Instruct them to pay special attention during the film to what instruments they see being played.

DAY 1:

1. After viewing the film, ask students to turn to their partner and practice taking turns describing what they remember from the film. After each student has the chance to speak for sixty seconds, ask them to reflect again on what instruments they remember seeing in the movie. Ask them to describe them in as much detail as they can. If appropriate, you can model this before they begin by describing what you remember about Louis Armstrong's horn.

2. Remind students that America is made up of people who moved from all over the globe to live in our nation. When they moved, they brought their musical instruments with them. Share with them the story of New Orleans and the birth of Jazz.

LESSON 1: INSTRUMENTS



Djembe
Drum

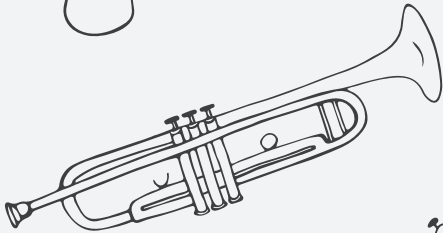

Trumpet

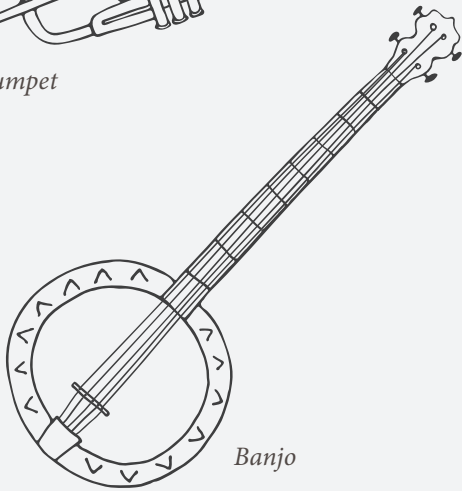

Banjo

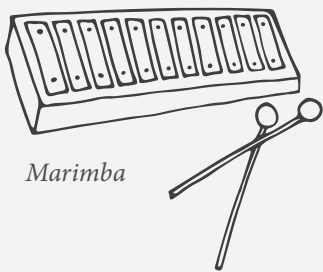

Marimba

TO DO (DAY 1 CONTINUED):

3. Show students the image of each of the instruments found in the *Teacher Handout* (Djembe Drum, Trumpet, Banjo, and Marimba). These can also be digitally displayed on an overhead. These instruments were all brought to New Orleans from people who came from all over the world. For each of the instruments, describe their place of origin and how they were played in music. It may be helpful to have a map of the world displayed where you can mark the origin of each instrument for students to visually see their locations.

4. Have students write the names of each instrument and color them in on the *Instruments Around the World* student sheet. Have students practice reading the sentences and sounding out each word.

5. Ask students to reflect:

- * *Why do we have so many different kinds of music in the United States?*
- * *Where did this music come from?*
- * *Why did it come here?*

DAY 2:

1. Ask students what they remember about the instruments from the last lesson. Remind students about Gloria Estefan in Miami. Gloria is bringing the world of salsa music to the United States. One instrument famous in salsa music is the scratcher. It makes a rattling and shaking noise. Today in class, we will build an instrument that makes a similar noise.

2. First, demonstrate to students how they will assemble the instrument (they will first decorate the outside of the paper towel roll, then they will choose what kind of material to put in the inside, then the teacher will fill the instrument, and cap it off with tape).

3. Tell the students that first, they must plan how they will decorate their instrument. Have students count out how many of each decoration type they want to glue to their paper towel roll from the baggies at their tables (please see teacher prep for more information) and record the number on their *Making My Instrument Sheet*.

4. Afterwards, call each table group up one at a time to choose what they want in their instrument. Fill their tubes with 1/4 to 1/2 cup of the material and cap off the open side of the tube with additional tape.

5. After each student has a finished instrument, ask them to shake their instrument and see what noises it makes. Have them turn to a partner and listen to their instrument. Afterwards, they should compare how their sounds similar and different.

6. As a challenge: ask students what loud music sounds like, then ask the class to try to play loud music. Ask the students what soft music sounds like, then ask the class to play a soft song.

LESSON 1: INSTRUMENTS



TO DO (DAY 2 CONTINUED):

7. As a finale, find a copy of Louis Armstrong's "What A Wonderful World" to play for the class. Tell them they are going to help Louis play the song by adding their instruments. Turn on the song and have the class shake their instruments!

EXTENSION ACTIVITIES:

As you and the students are learning about the different instruments that came to the United States, you can listen to songs played with each. Links to short YouTube videos for each are found below:

Djembe Drum: <https://www.youtube.com/watch?v=4qaNO1vLeWI>

Trumpet: <https://www.youtube.com/watch?v=BkUFSSeNKb8>

Guitar: <https://www.youtube.com/watch?v=8B6jOUzBKyc>

Marimba: https://www.youtube.com/watch?v=_SgeojuFhyU



Drum

The djembe drum was invented over 800 years ago! Imagine that! That is older than your great great great grandmother or father! It was invented in Africa. In Africa, they played the djembe drum to make music for people to dance. When Africans were brought to America much later, they brought this drum and its music. They played the drums in circles in New Orleans while people danced along.



Banjo

The banjo first appeared in Africa as an instrument made from gourds with strings. People who moved from Africa remembered how the banjo was played by plucking the strings to make a sound. When people from West Africa came to America, they made new banjos to play music and dance. The banjo became very popular in the Appalachian mountains. There, people played the banjo to create country music.



Marimba

Originally, the Marimba was from Western and Central Africa. In Kiswahili, the language people spoke in Western Africa, the name marimba means “mother who sings”. The marimba is thought to be one of the “mothers of all instruments”. What do you think that means? Later, when people from Western Africa moved to Central America, they brought the idea of the marimba with them. Unlike drums, the size of the marimba was too large. The marimba could not fit on a boat. But people still knew how to make one! In Central America, they made new marimbas with gourds. A gourd is a vegetable on the island.



Trumpet

The trumpet was first made thousands of years ago. The trumpet is from the Greek and Turkish area of the world. It was first made of horn and shell. It was used to make a loud signal to warn or notify people of something that is coming. Later, it was made out of metal, like the trumpets of today. In early American history, it was used during battle. Someone blew the trumpet to alert the troops when it was time to charge. People would take their trumpets home and use them to play music for their family.

Instruments Around the World

Marimba

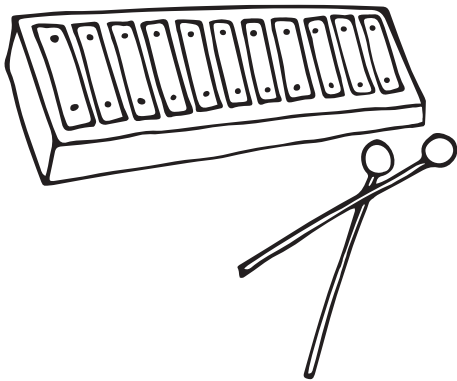

The _____ is from Central America.

The _____ means “mother sings”.

Trumpet

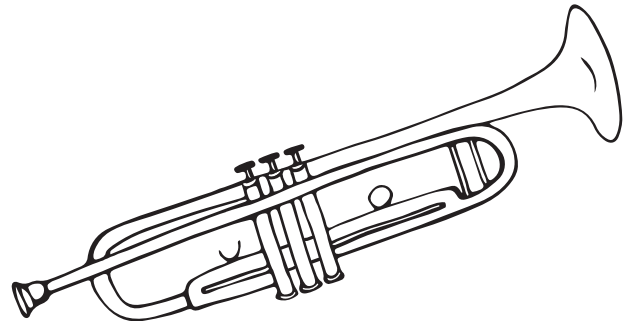

The _____ is from Europe.

The _____ sound sends signals.

Banjo

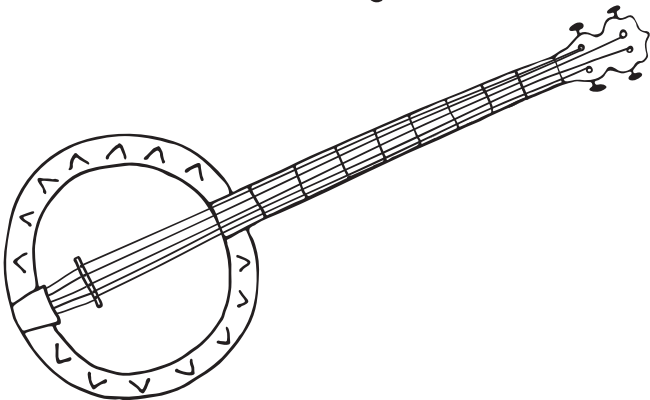

The _____ is from Africa.

Country musicians play the _____.

Drum

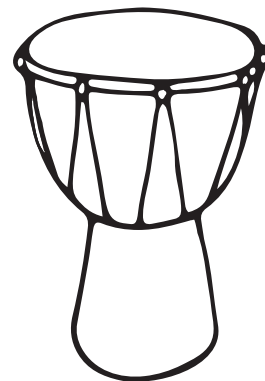

The _____ is from Africa.

People dance to the _____ music.

Making My Instrument



I will use ____ red triangles.

I will use ____ blue squares.

I will fill my instrument with

- RICE
- BEANS
- BEADS

LESSON 2: WANTS AND NEEDS

GRADE LEVEL K-1

(1) 15 MINUTE PREP LESSON

(3) 45 MINUTE LESSONS



GRADE LEVEL K-1
(1) 15 MINUTE PREP LESSON
(3) 45 MINUTE LESSONS

LESSON 2: WANTS AND NEEDS

ELA STANDARDS:

- Describe people, places, things, and events with relevant details, expressing ideas and feelings clearly.
- With guidance and support from adults, recall information from experiences or gather information from provided sources to answer a question.

SOCIAL STUDIES STANDARDS:

- Use maps, globes, and other simple geographic models to identify cultural and environmental characteristics of places.
- Explain how families have needs and wants.

LESSON OVERVIEW:

Students learn about the journey people take when they immigrate to the United States. Afterwards, they learn about the concept of human wants and needs. Finally, students put together what they learn to create a care package for people moving to the U.S. that meets their wants and needs in a new home.

FROM THE FILM:

America's Musical Journey talks about the journey people made to the United States in search of a new life. Aloe Blacc and his family immigrated to the United States from Panama. Many people currently living in Florida and Miami emigrated from Cuba. When people moved across the world to come to our nation, they brought their culture and their music. However, their material possessions were few. Often, all people could bring with them were their clothes, photos of their family, and a few other possessions.



LESSON 2: WANTS AND NEEDS

MATERIALS:

- Map Of The World*
(teacher image for projection or printing)
- Map Of The World Student Sheet* (optional)
- My Home Sheet*
- Care Package Sheet*
- Paper Plates
- Crayons
- Miscellaneous Decorating Materials
(stickers, string, beans, etc)
- Construction Paper
- Coupon Flyers and Magazine Advertisements



Prepare the paper plates for students.

TEACHER PREP:

DAY 1:

Prepare to project the world map on the screen. If printing off images for students, do so now.

DAY 2:

Print out a copy of the *My Home Sheet* for each student. Have ready a chart paper with a T Chart drawn on it.

DAY 3:

Print out copies of the *Care Package sheet* for each student.

Prepare the paper plates for students. This can be done ahead of time or as they are decorating them in class. On the paper plate, cut a 1 inch line from the edge of the plate towards the center. Repeat this for a total of six cuts, evenly placed along the circumference of the plate. At each cut, pull the edges of the cut so that they overlap by $\frac{1}{2}$ inch. Staple together.

Prepare the construction paper handles for students to braid. Cut construction paper into 1 inch strips along the length of the paper. Gather three strips of different colors, stack on top of each other, and staple at one end.

LESSON 2: WANTS AND NEEDS



Ask students to predict what each color represents on the image.

TO DO:

BEFORE VIEWING THE FILM:

Prepare students to view the film, *America's Musical Journey*.

Ask students to predict what the movie is going to be about from the title and image on the cover poster. Write down their thoughts on an anchor chart. Instruct them to pay special attention during the film to what “journeys” they see people taking.

DAY 1:

1. After viewing the film, ask students to think about the journeys people took in the film. Have them turn to their partner and take turns telling them what they remember. Afterwards, get some ideas from the class.

2. Display the image of the globe on the board. It is optional to give each student a copy of his or her own map. Ask students to predict what each color represents on the image. Afterwards, explain the color coding of the map and annotate it with explanations. If students have their own image, they can follow along with you and label their own.

* *What does the blue areas show on the map?*

This color shows that there is an OCEAN here.

What do you know about OCEANS?

[Jot down student responses]

* *What do you think the brown and grey areas show on the map?*

This color shows that there are MOUNTAINS here.

What do you know about MOUNTAINS.

[Jot down student responses. Key ideas are they are cooler than other areas, they can be rocky, and they can have forested lands]

* *What do you think the green areas show on the map?*

This color shows that there are FORESTS here.

What do you know about FORESTS?

[Jot down student responses. Key ideas are they have a lot of trees, can be hot or cold].

* *What do you think the yellow areas show on the map?*

This color shows that there are DESERTS here.

What do you know about DESERTS?

[Jot down student responses. Key ideas are they tend to be hotter and are very dry].

3. The map has the location of some of the major areas where emigration led to the peopling of the United States and development of the musical culture highlighted in *America's Musical Journey*. For each, ask students to think to themselves “what is that area of the world like? What can we tell from the map?” Then, students should turn to their partner and take turns explaining what they see. Afterwards, draw a line from that area on the map to New York, ask students to imagine the journey.

* *How is New York different from where they are from?*

4. Tell students that tomorrow, they will learn more about the journey to the United States.

LESSON 2: WANTS AND NEEDS

TO DO (CONTINUED):

DAY 2:

1. Ask students to share what they remembered from the last lesson where they looked at the map of people's journey to the United States.

2. Remind students that people came to the United States in search of a better life. They had to cross large oceans on boats to get there. This meant that they could not bring much with them.

3. Instruct students to draw a picture of the inside of their home on the *My Home sheet*. Instruct them to think of the things a visitor would see if they came into their house. What is in the living room? Kitchen? Bathroom? After students finish, they should turn to a friend and take turns explaining their drawing.

4. Create a t-chart on an anchor poster or the board. On one side write NEED and on the other WANT.

5. Explain to students that every human has NEEDS. A NEED is something that people must have in order to live, be hygienic, and be healthy. Offer up a need that you have in your own home. Ask students if they can identify any of the individual or family NEEDS they drew in their home. For each response, ask them to justify their thoughts, and write it down in the NEEDS column.

6. Explain to students that every human also has WANTS. A WANT is something that humans would like to have because it makes them happy, but is not necessary for survival. Offer up a want that you have in your own home. Ask students to identify any of the individual or family WANTS they drew in their home. Write down the list in the WANTS column.

7. Now, remind students that when people traveled across oceans to get to the United States, they could only bring what would fit in a small suitcase. When they look at the list they have generated on the board, are there any things that they would not be able to bring with them? Why?

DAY 3:

1. Remind students that during the last lesson, they learned about the tough decisions people faced as they left their home country to move to the U.S. People were only able to bring a small amount of things with them, and it was often only what they needed to survive. Even today, people still move to the United States in search of a better life. Today, we will build "care packages" for people newly arriving to the U.S. These care packages will meet their wants and needs.

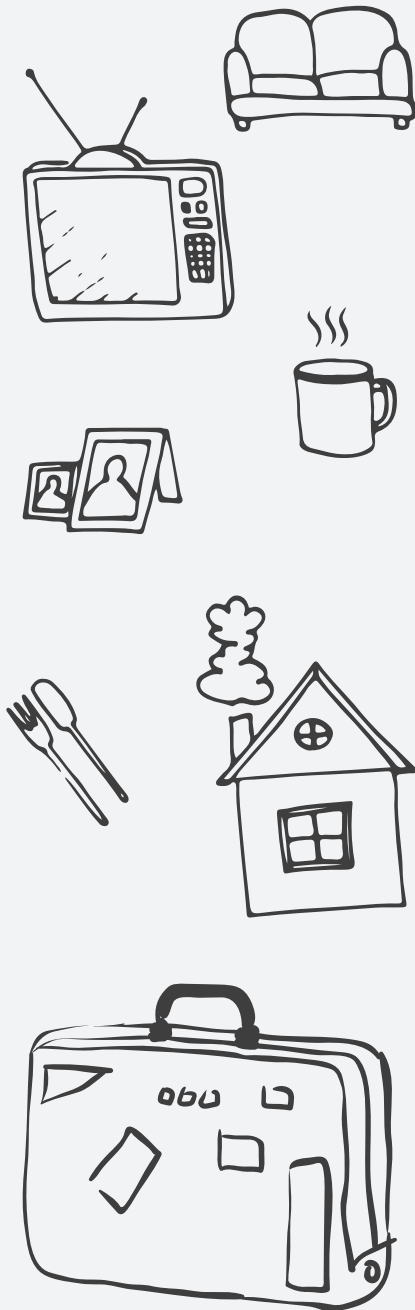

LESSON 2: WANTS AND NEEDS

TO DO (DAY 3 CONTINUED):

2. Have ready a set of materials for each student group. Each student will need a paper plate, drawing utensils, string, and whatever other decorating materials you would like to make available for students. Tell students that first they will make the baskets for the care package. Students will later fill the basket with materials to give to newly arrived Americans. Students will decorate the plate to look like a basket while an adult comes around to staple the edges of the plate together to form a bowl shape. (*See teacher prep notes*).

To encourage creativity, do not give students exact directions on how the care package basket should look. Instead, show images of different kinds of baskets and containers on the board and allow them to decide for themselves how they want to color and add material to the paper bowl.

3. Give each student (3) 1-inch thick strips of colored construction paper, stapled together at one end. Tell students that they are going to weave together a handle for the basket out of different colors. You can connect this to how America is made up of humans of all different colors and backgrounds, just like these baskets. Demonstrate how to braid the three strands together, and fix with a staple at the other end of the braid. Students can either glue these handles to the paper baskets they created or have an adult staple it for them.

4. After students have completed their baskets, it's time for them to select items for people moving to a new home. Give each student group a collection of coupon flyer pages and magazine pages/advertisements. Have students cut out 3 needs they think will help families new to the U.S., and glue/tape them in the NEEDS column of the *Care Package Sheet*. Next, have them select 3 WANTS from the pages, cut them out, and glue/tape them to the WANTS column.

5. Afterwards, have students share what they built with their families when they see them after school. Have students practice telling their families about the care package they made and why it helps people.



The World



The World

This is a map of the World. People traveled from all over to reach the U.S.



The BLUE on the map stands for _____.

The GREEN on the map stands for _____.

The BROWN and GREY on the map stand for _____.

The YELLOW on the map stands for _____.

My Home

Directions: Draw what is inside your home. If a friend came to visit...

What would they see in the kitchen?

What would they see in the bedroom?

What would they see in the bathroom?

A large rectangular box divided into three vertical sections. A large arrow points from the text above into the top of the box. The sections are labeled 'Kitchen', 'Bedroom', and 'Bathroom' from left to right.

Kitchen

Bedroom

Bathroom

Care Package

Directions: You will make a care package.
A care package holds presents.
The presents meet people's WANTS and NEEDS.
Cut out pictures of what you will put in the care package.
Paste the pictures below.

Wants	Needs

LESSON 3: COMMUNITIES

GRADE LEVEL 2-3
(1) 15 MINUTE PREP LESSON
(2) 45 MINUTE LESSONS



GRADE LEVEL 2-3
(1) 15 MINUTE PREP LESSON
(2) 45 MINUTE LESSONS

LESSON 3: COMMUNITIES

ELA STANDARDS:

- Write informative/explanatory texts in which they introduce a topic, use facts and definitions to develop points, and provide a concluding statement or section.

SOCIAL STUDIES STANDARDS:

- Use maps of different scales to describe the locations of cultural and environmental characteristics.
- Explain how the movement of goods, people and ideas impact the community.

LESSON OVERVIEW:

In this lesson, students investigate communities of different types and sizes. The teacher begins by discussing the school neighborhood as a community. Students then investigate the communities of Miami, Florida, the United States and Cuba.

FROM THE FILM:

Communities are formed when people gather together to live and share responsibility. In the film *America's Musical Journey*, we see the beautiful way that people of diverse background come together in Miami to form a community of musicians, dancers, and athletes.



LESSON 3: COMMUNITIES

MATERIALS:

- America's Musical Journey*
- Neighborhood Investigation Walk*
- Community Notes*
- Communities Come In Different Sizes*



Louis Armstrong



Dance group in Chicago

TEACHER PREP:

DAY 1:

During this lesson, students take an investigation walk around the perimeter of the school to make observations about their neighborhood community. Depending on your school location, this may be a challenge. Before this class, take the walk yourself, noting any difficult terrain or unsafe areas to avoid.

DAY 2:

During this lesson, you will be projecting images from Google Earth onto the front board for students to make observations on communities of different sizes. It is recommended that you test this out before class to ensure that the image is projected clearly. Cut 3-inch strings (3 are needed for each student). Students will use the strings to connect community circles together. The mobiles can later be hung from the ceiling or sent home with students.

TO DO:

BEFORE VIEWING THE FILM:

Prepare students to view the film, *America's Musical Journey*. Ask students what they know about musicians, or people who play music for a living. Ask students what they hope to learn about music in *America's Musical Journey*. Record responses in the K and W columns of a KWL chart. Tell students to pay special attention to what they learned during the film about music and musicians.

DAY 1:

1. Gather the students together and ask them to record what they learned about musicians from the film. Have students share what they wrote with a class, recording their ideas on sentence strips and placing them on the KWL chart. If no student mentions it, mention that one thing you learned about musicians, is that they always worked together in a team. These teams could be small, like Louis Armstrong's band, or very large, like the dance group in Chicago.

2. Explain that when people gather together to live, work, and play together, they form a community. Musicians work in communities. Our school neighborhood is a community. Define community for the class. Have students record it in their *Community Notes* sheet. Explain that a community is made of the people that live within it, and a community often has leaders that help make decisions for the whole group.

LESSON 3: COMMUNITIES



TO DO (DAY 1 CONTINUED):

3. Tell students that first, they will begin by taking an investigation walk around the school campus. During this walk, students will bring the *Neighborhood Investigation Walk* sheet with them as they walk along the perimeter of the school property. As they walk, pause at least four times and have them write down what they see in the neighborhood.

* *What kinds of buildings do they see? (If any)*

* *What kinds of roads?*

* *Do they see any people?*

* *What are the people like?*

4. Ask the students:

* *Who are the people that we saw during our neighborhood community walk?*

* *If we didn't see any people, what do we already know about the people that live in this community?*

* *Who is the leader of this school neighborhood community?*

5. Explain that communities are classified by the types of buildings that are most common and the amount of people that live close to one another. The three types of communities are: urban, suburban, and rural. Have students write down a definition for each of the three types of communities. Consider displaying an image of each on the board for students to visualize the difference between each group.

6. What kind of community is your school neighborhood?

7. Ask students to recall from the film, did they see any urban communities? Suburban? Rural? Have students describe one location in terms of its community type and just justification for why it is that kind of community.

DAY 2:

1. Ask students to do a think pair share about what they remember from the last lesson on communities.

2. Remind students of the Miami community in the film. They saw many different kinds of people who live within Miami: musicians, dancers, and surfers. Today, they are going to learn about the different communities the people of Miami live in.

3. Explain to students that communities come in different sizes. Miami is a city. A city is a community that is led by a Mayor and City Council. On the projection board, pull up Google Earth and search for Miami. Ask students what they notice about the image. Have them share their thoughts with the class. On the board, model for the students how to research the name of the Mayor of the city and the size of the population. Students should fill in the answers on the *Communities Come In Different Sizes* sheet.

LESSON 3: COMMUNITIES

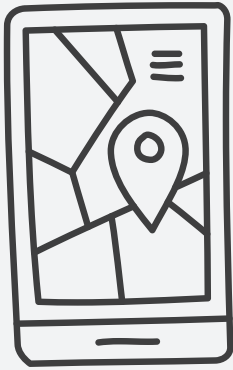

TO DO (DAY 2 CONTINUED):

4. Now explain that cities are smaller communities located inside of larger communities called states. Everyone who lives in Miami, also lives in the state of Florida. Navigate back to Google Earth and enter Florida. Ask students to note what they see is different from the image of Miami. It is optional to model researching the community information on the board for students, or, if resources and ability allow, have them research them on personal devices. Students should fill in the answers on the *Communities Come In Different Sizes* sheet.

5. Note that Florida is also a smaller community inside of a larger community called a nation. Everyone who lives in Miami, also lives in Florida, and also lives in the nation of the United States of America. Enter the United States of Florida into Google Earth. Ask students to note the differences they observe between Florida and the nations of the United States. Enter the community information on the sheet.

6. Have students cut out the circles on the *Communities Come In Different Sizes* sheet. Have them poke holes in the dotted areas. Students should use string to connect the communities one of top of the other with the largest community on top and the smallest on the bottom.

7. Finally, explain that the United States is a smaller community inside of the largest community of all, the world. The world is made up of many nations. Remind students that many people who live in Miami once came from Cuba. Navigate to Cuba in Google Earth. Ask students to note what they see is different and similar between Cuba and the United States.

EXTENSION ACTIVITIES:

Have students examine Cuba and identify the different levels of communities as in the Day 2 lesson. What are the different states and capitols of the country? Using Google Earth, look at each different area and have students identify if they are rural, suburban, or urban. Afterwards, students can repeat the same activity with other nations mentioned in *America's Musical Journey* including Panama, Aloe Blacc's home country.

America's Musical Journey

Directions: First, write down what you learned about musicians. After, write down what the class learned.

What I Learned:

I learned that musicians: _____
_____ .

What We Learned:

- _____
_____ .
- _____
_____ .
- _____
_____ .
- _____
_____ .
- _____
_____ .

Neighborhood Investigation Walk

Directions: You will take an investigation walk of your school neighborhood. Write down or draw what you observe.

What kinds of buildings do you see?

What kinds of people do you see?

What is the land like?

What animals do you see?

Notes	Drawings

Community Notes

A Community Is: _____
_____.

Three Types of Communities:

Urban	Suburban	Rural

Communities Come In Different Sizes

Directions: For each type of community, fill in the leader and size of population. When you are finished, cut out the circles along the dotted line. Poke holes through the x symbols. With 3 pieces of string, connect the community circles together so that they are in a chain one after the other. Place the largest community on top and the smallest on the bottom.

Miami

Miami is a _____.

Miami's leader is called a _____.

_____ people live in Miami.

Communities Come In Different Sizes

Directions: For each type of community, fill in the leader and size of population. When you are finished, cut out the circles along the dotted line. Poke holes through the x symbols. With 3 pieces of string, connect the community circles together so that they are in a chain one after the other. Place the largest community on top and the smallest on the bottom.



Communities Come In Different Sizes

Directions: For each type of community, fill in the leader and size of population. When you are finished, cut out the circles along the dotted line. Poke holes through the x symbols. With 3 pieces of string, connect the community circles together so that they are in a chain one after the other. Place the largest community on top and the smallest on the bottom.

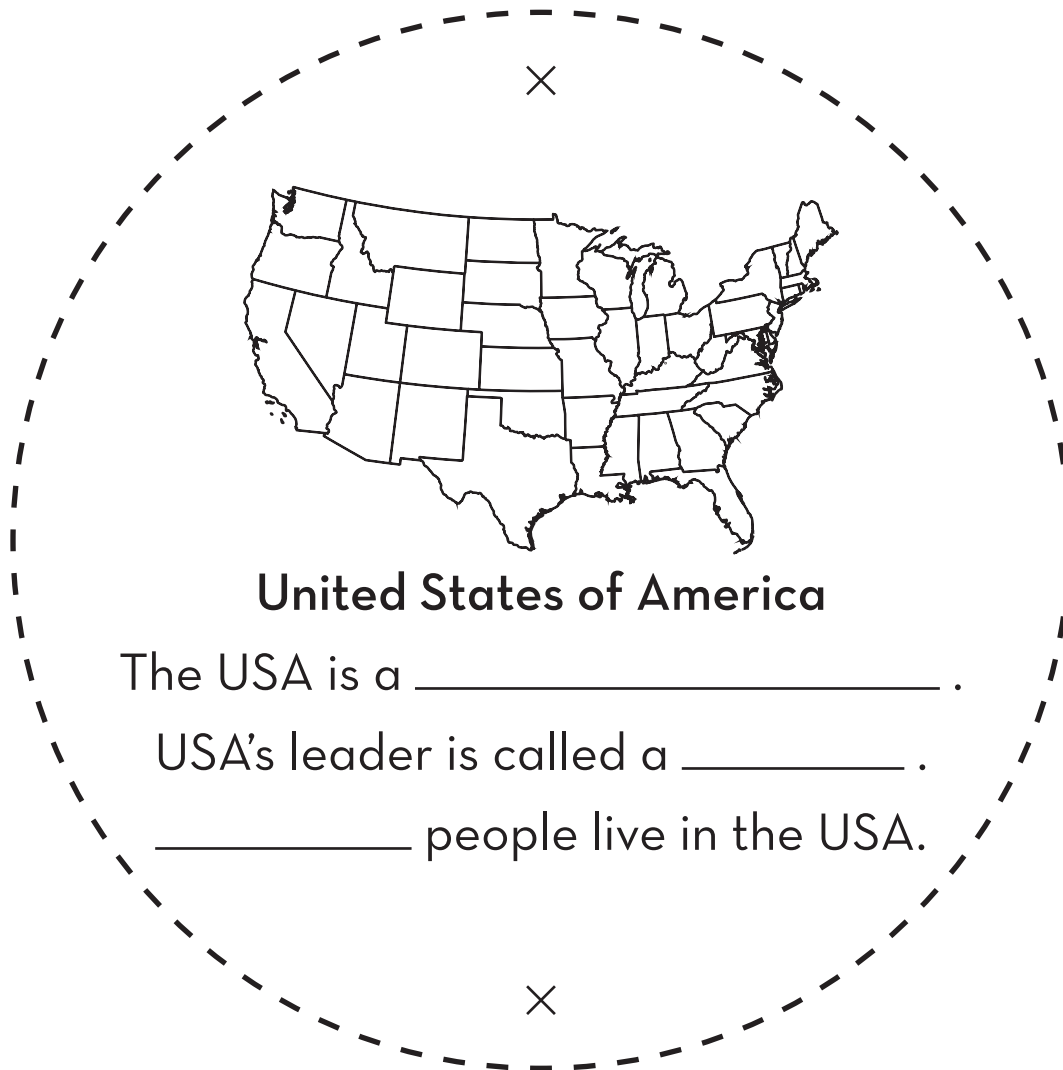

United States of America

The USA is a _____ .

USA's leader is called a _____ .

_____ people live in the USA.

LESSON 4: CULTURE

GRADE LEVEL 2-3
(1) 15 MINUTE PREP LESSON
(3) 45 MINUTE LESSON



GRADE LEVEL 2-3
(1) 15 MINUTE PREP LESSON
(3) 45 MINUTE LESSON

LESSON 4: CULTURE

ELA STANDARDS:

- Write informative/explanatory texts in which they introduce a topic, use facts and definitions to develop points, and provide a concluding statement or section.

SOCIAL STUDIES STANDARDS:

- Identify some cultural and environmental characteristics of specific places.
- Explain the elements of culture (how people speak, how people dress, foods they eat, etc.).

LESSON OVERVIEW:

During this lesson, students learn about the different aspects of culture and how immigration builds the unique culture of different American cities. After the first day, students interview a relative and prepare to bring in an artifact of the culture of their parents heritage.

FROM THE FILM:

America is a multicultural quilt. As people move to the U.S., they bring with them the culture of their home country. Throughout the film, we see how immigration to the United States has contributed to building the rich and unique culture of many different cities.



LESSON 4: CULTURE

MATERIALS:

- Culture of Our School Community Sheet*
- AMJ Culture Teacher Handout*
- Culture of My Family*
- Optional: Construction paper cut into triangles or 2 inch strips

TEACHER PREP:

Before this unit, it is helpful to communicate with parents because of their involvement in several of these lessons. Inform parents ahead of time that students will be learning about culture and to be prepared to answer questions about the culture of their heritage. It is also important to notify parents ahead of time of the date you plan for the “cultural heritage day” and that students will be expected to contribute an artifact of their family’s culture.

DAY 1:

Print off enough copies of *Culture of Our School Community* for students to share a sheet with a partner. Print off enough copies of the *AMJ Culture Teacher handout* for student pairs to have one city image each. Print off enough copies of *Culture of My Family* for each student to have one.

DAY 2:

Have ready lined paper for students to write paragraphs.

DAY 3:

If you are going to have students write what they learned on the pieces of construction paper, chose to either cut construction paper into two inch links of triangles and give each student enough to write several things that they learned from the presentations on each one. It is also helpful to speak with parents and students ahead of time to know what cultural artifact they will bring and if you need to prepare anything to support them (i.e. having paper plates for students that bring food, speakers for students who bring music, etc.).

TO DO:

BEFORE VIEWING THE FILM:

Prepare students to view the film, *America’s Musical Journey*. Ask students to think of a time they visited a town or person’s home other than their own. Have students think of how the city or home was different from their own. Ask them to think of how it was similar. Have students think pair share with a partner and give their thoughts. Explain to students that much of what they described is part of what people describe as culture. The culture of an area describes is language, religious beliefs, traditions, and art. Music is a large part of an area’s culture. Students are about to view a film that talks about the different types of music in America and the culture of their origin. Ask students to pay special attention to what cities the movie features and the culture they see within it.

LESSON 4: CULTURE

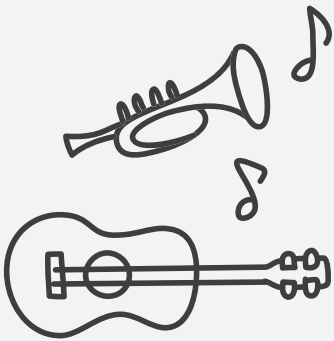

TO DO (CONTINUED):

DAY 1:

1. Ask students to write down one city they remember being mentioned in the film *America's Musical Journey*. After the city, have them write down at least two things they remember being shown or said about that city. Have students ball up the paper, and when you call "SNOWBALL!" through them high up into the air. After all the papers have landed, instruct students to each find one paper snowball, unfurl it, and read what another person has put. Have a few students share what they have for the class.

2. Note that much of what they are describing is the "culture" of a city. Define culture for students. Note that culture has many different factors or aspects. Culture includes the kinds of food people eat in an area, the flag of that community, the language that is spoken, the music that is heard, etc. To start, have students work with a partner and reflect on the culture of your school. Have students collaboratively fill in the *Culture of Our School Community* sheet.

3. Now, tell students that they are going to look deeply at the culture of the American cities featured in *America's Musical Journey*. Hand each pair of students one of the screen shot pictures in the *AMJ Culture Teacher Handout*.

4. Ask students to circle all the different aspects of culture they are able to see within the image. At the end, introduce students to their homework. When they go home for the night, they should use the *Culture of My Family* sheet to interview their parents or guardians about the culture of their family's heritage. Tell the class that you are going to host a cultural heritage day. On this day, students will write about their family's culture and share one aspect of it with the class. This could mean bringing in food from their culture, a piece of artwork, music, or any other aspect of culture. Mark the day on the calendar and send home a note to parents to remind them of the students' responsibility for sharing that day.

DAY 2:

1. Remind students that during the next lesson, they will have a cultural heritage day. Just like the film *America's Musical Journey* shows ways that people of diverse backgrounds can come together to make new and beautiful music, you are excited to see the diverse backgrounds in your own classroom!

2. Have students get out the *Culture of My Family* sheet. Tell them that before they share their artifact and what they learned about their culture with the class, they must first plan what they will say. This means they must write a paragraph that they can read from.

3. Review with students how to properly write an informational paragraph with a topic sentence, supporting details, and concluding paragraph.

LESSON 4: CULTURE

TO DO (DAY 2 CONTINUED):

4. Instruct students to use the *Culture of My Family* sheet to write a short paragraph describing their cultural heritage.
5. Have students practice speaking the paragraph out loud with a partner.

DAY 3:

1. Welcome students to the cultural showcase day! Remind students that they are going to present a speech to the class about their family's cultural heritage. As students are sharing their cultural heritage, they should showcase what they brought in with the class. This may mean sharing food or showing a music video clip, so prepare ahead of time if additional coordination may be needed.
2. If you would like, students can write down one new thing they learned during each student's presentation on small pieces of construction paper cut into 2-inch strips or triangles. At the end of class, you can have the students link the construction paper into a chain or connect the triangles with string to make a multicolored reflection of all the different aspects of American culture in your classroom.
3. Call students up one at a time to present their cultural heritage paragraph and talk about their artifact.

EXTENSION ACTIVITIES:

To investigate the cultures of the peoples that formed our nation, consider reading books with students that highlight the traditions that influence our modern music. For example, *Dance, Nana, Dance* by Joe Hayes retells the cultural folklores of Cuban Americans in the same rhythmic tones that underlie the musical traditions from that area.



Culture of Our School Community

Directions: Find a partner. Write the name of the school in the center circle. In each of the surrounding circles, decide with your partner, what would fit in that for your school's culture. For example, under "music" you may think of a school song, or a jingle that is played during announcements. Is there a song your teacher commonly plays in the classroom?

Flag/
Symbol:

Music:

Art:

School Name:

Beliefs:

Food:

Clothing:

Culture of *America's Musical Journey* Cities

Directions: Below is an image from *America's Musical Journey*. For the image you are given, circle the different aspects of culture that you see in the city. Label it as one of the types of culture (music, art, clothing, food, beliefs, flag/symbol).

City: Chicago

Circle At Least 3 Aspects of Culture!



Summarize: Describe the culture of this city! Use two adjectives.

Culture of America's Musical Journey Cities

Directions: Below is an image from *America's Musical Journey*. For the image you are given, circle the different aspects of culture that you see in the city. Label it as one of the types of culture (music, art, clothing, food, beliefs, flag/symbol).

City: New York

Circle At Least 3 Aspects of Culture!



Summarize: Describe the culture of this city! Use two adjectives.

Culture of *America's Musical Journey* Cities

Directions: Below is an image from *America's Musical Journey*. For the image you are given, circle the different aspects of culture that you see in the city. Label it as one of the types of culture (music, art, clothing, food, beliefs, flag/symbol).

City: Miami

Circle At Least 3 Aspects of Culture!



Summarize: Describe the culture of this city! Use two adjectives.

Culture of *America's Musical Journey* Cities

Directions: Below is an image from *America's Musical Journey*. For the image you are given, circle the different aspects of culture that you see in the city. Label it as one of the types of culture (music, art, clothing, food, beliefs, flag/symbol).

City: Nashville

Circle At Least 3 Aspects of Culture!



Summarize: Describe the culture of this city! Use two adjectives.

Culture of My Family

Directions: Interview your parents about their culture. Where are they from? How would they describe it in two words (adjectives)? What cultural aspects do they know of in each category? Fill in the responses below.

The diagram consists of a central circle connected to six surrounding circles. The central circle contains the text: "My Family is From:" followed by a blank line, "2 adjectives that describe the culture are:" followed by two blank lines. The surrounding circles are labeled: "Music / Art:" with two blank lines; "Language:" with two blank lines; "Clothing:" with two blank lines; "Food:" with two blank lines; "Beliefs:" with two blank lines; and "Flag/ Symbol:" with two blank lines.

Music / Art:

Language:

My Family is From:

2 adjectives that describe the culture are:

Clothing:

Food:

Beliefs:

Flag/ Symbol:

LESSON 5: ELLIS ISLAND

GRADE LEVEL 4-5

(1) 15 MINUTE PREP LESSON

(2) 45 MINUTE LESSONS



GRADE LEVEL 4-5
(1) 15 MINUTE PREP LESSON
(2) 45 MINUTE LESSONS

LESSON 5: ELLIS ISLAND

ELA STANDARDS:

- Write narratives to develop real or imagined experiences or events using effective techniques, descriptive details, and clear event sequences.

SOCIAL STUDIES STANDARDS:

- Exemplify migration within or immigration to the United States in order to identify push and pull factors (why people left/why people came).

LESSON OVERVIEW:

In this lesson, students learn about the experience of immigrating to the United States through reenacting the journey through Ellis Island to New York. Afterwards, students use their experience to write a first person narrative of a musician's journey immigrating to the United States.

FROM THE FILM:

When Aloe Blacc visits New York City, he takes a boat to visit Ellis Island. Ellis Island and the Statue of Liberty are symbols of America's promise to people searching for a better life. The diverse cultures that formed the innovation in New York's music industry once passed through Ellis Island as they journeyed across oceans to come to America.



LESSON 5: ELLIS ISLAND

MATERIALS:

- Prepare for the Journey Handout*
- Ellis Island Inspection Checklist Handout*
- Journal Entry Handout*
- Construction paper
- Scissors
- Glue sticks
- Games for students to play
- Simple musical instruments (drums, xylophone, etc)
- Drawing paper
- Crayons or other drawing tools

TEACHER PREP:

DAY 1:

Before teaching this class, it is helpful to seek parent volunteers who can run any of the inspection stations or keep students on task when they are in the Great Hall. Before you teach the lesson, reach out to the volunteers with a description about what their role will be in the simulation and what they will do at their station.

You will need to set up your room to have three areas, the boat, Great Room, and inspection stations. To create the boat, tape off an area of the room that is just large enough to hold the students. They should get an idea of how cramped it was in the steerage sections of vessels traveling across the sea. Tape off and label an area as the “Great Room” of Ellis Island. The Great Room should have games for students to play, simple musical instruments, and paper and drawing utensils. Set up three different stations and label them as follows: the Medical Station, Mental Station, or Legal Station.

TO DO:

BEFORE VIEWING THE FILM:

Prepare students to view the film, *America’s Musical Journey*. Ask students to raise their hand if they ever had to move homes. Ask two or three of the students to describe what they had to do to get ready to move and what the journey itself was like. Ask students to describe how their new town was different from their old town. Inform students that *America’s Musical Journey* tells the story of people moving to new places. As people moved, they met new friends and created new forms of music. As students watch the movie, ask them to pay special attention to the new kinds of music that were made as people moved to America.

DAY 1:

1. Ask students to share what they remember from *America’s Musical Journey*. If it is not mentioned, tell students that you remember the part about New York City. New York City is a major hub of music innovation. When different people and different cultures move to New York, they invent new ways to do art, play music, and work together.
2. Inform students that today, they are going to reenact the journey a person would take in the early 1900s to move to the United States. During this reenactment, they will gather details that they will use in the next lesson to write a journal entry of a musician moving to New York.

LESSON 5: ELLIS ISLAND

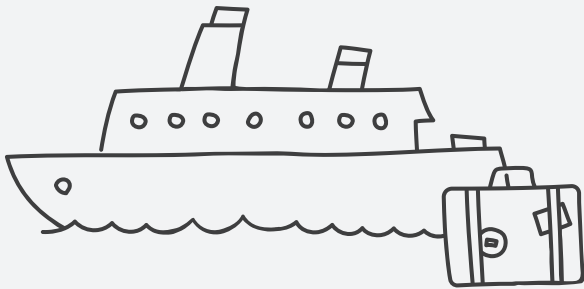

TO DO (DAY 1 CONTINUED):

3. First, have students “prepare for the journey”. Using the *Prepare For the Journey* handout, students will create a passport for their trip to the United States.

4. When students are ready, have them form a line outside of the area you labeled as “boat steerage” in the room. One by one, have them board the boat and stamp their passport as they enter. (It is optional to choose 3-4 student names from a hat to be the “first class passengers”. These students would be able to cut the line to get on the boat, and not have to stay confined to the small area you labeled in the classroom. They would be free to walk around and relax.)

5. Once all students are in the area labeled “boat steerage”, ask them to reflect about how much room they have. Inform students that often, the steerage on the boat had no windows and no showers. Ask students to verbally reflect on the following questions:

- * *What challenges did these immigrants face when they crossed the ocean?*
- * *What would it be like to make this two-week journey?*
- * *Why do you think people still chose to make this difficult journey?*

Jot down student responses on an anchor chart labeled “the journey across the ocean”.

6. Afterwards, tell students that they have “arrived” at Ellis Island. Give each student an Ellis Island Inspection sheet. Have students sit down in the area you labeled as the “Great Hall”. In the Great Hall, people waited to be called to the different inspection stations before they could leave to go to the city. Often, this took many hours. Because people waited such long times, they often met new friends in the Great Hall, created new games, played music, or made art together. Partner students together and allow them to work on a drawing/piece of art together, play music instruments, or play a game.

7. Call the students to the inspection stations one at a time.

- At the medical station, you or a parent volunteer should have students check their vision (read letters you post on a wall), physical movement (do jumping jacks), and check hearing (have them sing a common lullaby like *Mary Had A Little Lamb*).
- At the mental exam station, you or the parent should have the students count backwards from 20, solve two multiplication problems, and read a piece of text (can be a page from a story book).
- At the legal station, you or a parent volunteer should go through the legal section checklist and make sure all the answers are on the passport or the students answer them for you.
- After students are done with the inspection stations, they should go back to the Great Hall area and continue to draw, play games, or play music.

LESSON 5: ELLIS ISLAND



TO DO (DAY 1 CONTINUED):

8. After all students have gone through inspection, congratulate them and tell them they have all been approved to enter New York City and immigrate to America! Ask students to debrief and describe what it was like to pass through Ellis Island. Ask students to reflect on how they felt throughout the experience. Write down their responses on an anchor chart labeled “passing through Ellis Island”.

DAY 2:

1. Inform students that today, they will create a journal entry to share their experience on the simulation moving to New York. Have students pair up with the same partner they had in the Great Hall at Ellis Island. As a warm up, have students do a think, pair, share with a partner on what they remember from the Ellis Island reenactment.
2. Have students use their thoughts from the think pair share, and the notes you wrote on the “journey across the ocean” and “passing through Ellis Island” charts to fill out the pre-writing planning sheet.
3. Afterwards, remind students of the key elements for writing first person accounts of a fictional story.
4. Allow student to create their journal entries, describing their journey across the ocean and through Ellis Island to come to New York City.

EXTENSION ACTIVITIES:

Investigate the movement of peoples to the United States with digital mapping of immigration data. Use the following resource to display animated representation of the data for students on the board.

<http://metrocosm.com/animated-immigration-map/>

Consider integrating Google Maps into the simulation for students to visually see the terrain of people’s journey to America. Choose a location to begin the journey, ask students to make observations of what the area is like, then as you travel across the ocean and arrive at Ellis Island, ask students how the environment and human structures change. Ask students to predict how someone would feel as they saw the Statue of Liberty appear on the horizon.

Prepare for the Journey

Directions:

1. Fill in your information in the Passport section. Draw an image of yourself in the picture box.
2. Use scissors to cut along the dotted line.
3. Fold a piece of construction paper in half hamburger wise.
4. On the front page of the folded construction paper, write "PASSPORT".
5. Open the folded construction paper. On the inside of the folded paper, glue your passport information.

Passport:

Name: _____

Birth Date: _____

Country: _____

Address: _____

Picture:

Ellis Island Inspection Checklist

Health Examination:			Mental Examination:		
Vision:	Pass	Fail	Counting:	Pass	Fail
Physical Motion:	Pass	Fail	Multiplication:	Pass	Fail
Hearing:	Pass	Fail	Reading:	Pass	Fail

Legal Examination:
Name: _____
Country of Origin: _____
Destination City: _____
Family in the United States: _____
Occupation They Wish to Find In the US: _____

Journal Entry

Directions: First, fill in the pre-writing planning sheet. Afterwards, write a first-person narrative about someone who travels across the Atlantic Ocean to move to New York City.

Name	
Occupation	Musician, Plays Guitar
Country of Origin	Ireland
Journey Across the Ocean	What details do you remember from the trip (what did you see, hear, feel, smell)? How did you feel? (emotion words like, sad, happy, scared, etc).
Ellis Island Inspection	What details do you remember during each of the three examinations (what did you see, hear, feel, smell)? How did you feel? (emotion words like, sad, happy, scared, etc).
Waiting in the Great Hall	What details do you remember from waiting in the Great Hall (what did you see, hear, feel, smell)? How did you feel? (emotion words like, sad, happy, scared, etc).
End of the Entry	You pass all your inspections and get to enter New York City!

Journal Entry

Dear Diary,

LESSON 6: THE GREAT MIGRATION

GRADE LEVEL 4-5
(1) 15 MINUTE PREP LESSON
(2) 45 MINUTE LESSONS



GRADE LEVEL 4-5
(1) 15 MINUTE PREP LESSON
(2) 45 MINUTE LESSONS

ELA STANDARDS:

- Write opinion pieces on topics or texts, supporting a point of view with reasons and information.
- Write narratives to develop real or imagined experiences or events using effective technique, descriptive details, and clear event sequences.

SOCIAL STUDIES STANDARDS:

- Compare life in specific historical time periods to life today.
- Compare information provided by different historical sources about the past.
- Generate questions after comparing primary and secondary sources and their relationships to particular historical events and developments.

LESSON 6: THE GREAT MIGRATION

LESSON OVERVIEW:

In this lesson, students learn about The Great Migration through viewing primary source photographs and paintings. The Great Migration occurred after slaves were freed in the South and able to move around the country. Many former slaves chose to move to the north in order to avoid the hostile political environment of reconstruction in the South. Students are challenged to make observations of the photograph and draw conclusions about what they can learn from viewing them. Afterwards, students compare how life is different in the migrations of current day America to that of The Great Migration. Finally, students dream about how migration and the world might change in the future.

FROM THE FILM:

Louis Armstrong was one of the New Orleans natives affected by the Great Migration. As he and millions of other African Americans made the journey North, the new environment shaped their experiences. Ultimately, their resilience, strength, and innovation reinvigorated northern cities with a new culture.



LESSON 6: THE GREAT MIGRATION

MATERIALS:

- History Through Images*
- Students will need internet capable devices to view images on the Digital Public Library of America: <https://dp.la/primary-source-sets/sets/the-great-migration>
- Pencil
- Paper

TEACHER PREP:

DAY 1:

During each day of this lesson, students will view primary source images from The Great Migration period. The images are found on the *Digital Public Library of America*. It is worthwhile to view the collection ahead of time, and note important details that help students understand history through viewing images.

This lesson speaks about the Reconstruction era in American history. This period is known for its high racial tension and violence. In order to prepare students to speak honestly and compassionately about this time of our history, it may be helpful to open with a discussion about appropriate norms when talking about tough issues on diversity. For more information and activities for effectively teaching compassion and understanding of diversity, visit teachingtolerance.org.

TO DO:

BEFORE VIEWING THE FILM:

Prepare students to view the film, *America's Musical Journey*. Ask students to raise their hand if they ever had to move homes. Ask two or three of the students to share how things changed when they had to move. Inform students that *America's Musical Journey* is about the journey's people have made to the United States and within it. As people moved from place to place, their perspective helped to shape a new culture wherever they went. Ask students to pay special attention to the journeys people take throughout the film.

DAY 1:

1. Give students a map of the world. With a partner, ask them to circle areas on the map they remember from the film, and draw arrows connecting places that represent journeys featured in the story. When they are finished, you can project the map on the front board and ask students to share their memories, filling in the map as you go.
2. If students have not already mentioned it, circle New Orleans and Chicago. Remind students that the film talked about Louis Armstrong's journey north during The Great Migration. Explain that The Great Migration was part of the Reconstruction era of American history

Note: If students are not already familiar with the civil war and the period after, spend a brief moment explaining the overall context of the Reconstruction period.

LESSON 6: THE GREAT MIGRATION



TO DO (DAY 1 CONTINUED):

3. During this class, students will view images in the Digital Public Library of America. This is a library that contains images of books, pictures, and news articles that we can see from a computer, rather than having to visit the library. Navigate to <https://dp.la/primary-source-sets/sets/the-great-migration>, and introduce students to The Great Migration collection.

4. Introduce students to the *History Through Images* activity. In this activity, students will look at pictures and paintings of The Great Migration that were taken or made during that time. Historians call documents made during specific periods “primary documents”. Because time machines do not exist (yet), we cannot just jump back and ask people what happened in the past. Instead, historians rely on primary and secondary sources to learn about historical events. Today, they will think like historians and learn about people in the North and the South during The Great Migration.

5. Model for students how to analyze the first image. Students should note details they observe in the image and describe them on the *History Through Images* sheet. Have students work in pairs to investigate the rest of the images.

6. After students are finished, debrief as a class answering the questions:

- * *Why do you believe African Americans chose to leave the South and move North after they were freed?*
- * *What do you think these Americans expected life to be like in the North?*
- * *How do you think the reality of their life was similar and different to their expectations?*

7. Connect the student’s debrief conversation to what the film talks about in Louis Armstrong’s life. He left the South in search of a safer life and better job possibilities. When he got to the North, he indeed did start a successful musical career, but was still barred from staying at the hotels he played in.

DAY 2:

1. As a warm up, have students share what they remember about The Great Migration period from the last class. Inform students that they are going to revisit the images from the previous day to think about what the journey itself was like for African Americans moving north.

2. Have students navigate back to The Great Migration collection in the *Digital Public Library*. Ask students to use the same four images and any other sources of their choice to answer the following questions with their partner:

LESSON 6: THE GREAT MIGRATION



TO DO (DAY 2 CONTINUED):

- * *How did people travel from the South to the North?*
- * *What kinds of clothes did people wear?*
- * *What kinds of suitcases did they bring?*
- * *What kinds of jobs did people get in the city?*

3. Now, remind students that people still move across the country. In fact, currently there is an opposite direction of migration from the 1900s. People are moving away from northern cities and back to the South. (See extension activities for an investigation of why people are moving to the South). Ask students to look at the same four questions, and state how the answers would be different today. After students are done discussing their answers, ask them to evaluate whether they believe migrating today would be easier or harder than in the early 1900s and to support their claims with evidence.

4. Now, have students prepare to write a fictional prediction of what they believe a similar journey would be like in the future. Have students explain how families will move across the United States in the future. Their reflection should include answers to the following questions:

- * *Why will people need to move in the future?*
- * *How will they move their belongings?*
- * *What kinds of jobs will they take in their new homes?*

EXTENSION ACTIVITIES:

This lesson can be sensitive for those who have lost their homes or have had to move in order to stay safe from threats. *Teachingtolerance.org* has a wonderful lesson that helps students to build understanding and empathy for those who are still having to move across the country and globe to find a better life. Follow the link to learn more:

<https://www.tolerance.org/classroom-resources/tolerance-lessons/the-shape-of-home>

Why are people moving from the North to the South? Students may choose to learn more about current migration patterns within the United States. Students may read articles, encyclopedia entries (<http://www.encyclopedia.com/places/united-states-and-canada/miscellaneous-us-geography/sun-belt>), or view online news videos explaining this new phenomena.

History Through Images

Directions: Think like a historian! Historians look at images and paintings from the past. They use these sources to learn about what life was like.

1. You will follow the link below to get to the Digital Public Library of America.
2. Click on the six images below. Two are of African Americans living in the South before they moved. Two are of African Americans in the process of moving. Two are from after people moved.
3. Look at each picture and painting and answer the questions.

Link: <https://dp.la/primary-source-sets/sets/the-great-migration>

History Through Images

<p><i>Employment of Negroes in Agriculture,</i> An Oil Painting by Early Richardson 1934.</p>	<p>What detail did I notice?</p> <p>What does this make me think life was like?</p> <p>What question do I have after seeing this?</p>
<p>Cotton Sharecroppers in Georgia in a photograph by Dorothea Lange, 1937.</p>	<p>What detail did I notice?</p> <p>What does this make me think life was like?</p> <p>What question do I have after seeing this?</p>
<p>A photograph of a Jim Crow rail car “for Negroes only,” Fayetteville, NC, 1929.</p>	<p>What detail did I notice?</p> <p>What does this make me think life was like?</p> <p>What question do I have after seeing this?</p>

History Through Images

<p>A painting of the Great Migration by Jacob Lawrence, 1917.</p>	<p>What detail did I notice?</p> <p>What does this make me think life was like?</p> <p>What question do I have after seeing this?</p>
<p>A photograph of an African American family arriving in Chicago after migrating from the rural South, 1922.</p>	<p>What detail did I notice?</p> <p>What does this make me think life was like?</p> <p>What question do I have after seeing this?</p>
<p>A 1922 photograph from Chicago captioned “Negro women employed on power machines in a large apron factory.”</p>	<p>What detail did I notice?</p> <p>What does this make me think life was like?</p> <p>What question do I have after seeing this?</p>

LESSON 7: CULTURAL PROJECT

GRADE LEVEL 6-8

(1) 15 MINUTE PREP LESSON

(3) 45 MINUTE LESSONS



GRADE LEVEL 6-7
(1) 15 MINUTE PREP LESSON
(3) 45 MINUTE LESSONS

LESSON 7: CULTURAL PROJECT

ELA STANDARDS:

- Conduct short research projects to answer a question (including a self-generated question), drawing on several sources and generating additional related, focused questions that allow for multiple avenues of exploration.

SOCIAL STUDIES STANDARDS:

- Summarize the origin of beliefs, practices, and traditions that represent various groups within the United States (e.g. Moravians, Scots-Irish, Highland Scots, Latinos, Hmong, Africans, and American Indians)

LESSON OVERVIEW:

In this project-based series of lessons, students begin by asking the question “how have our American cultural practices been influenced by the many groups highlighted in *America’s Musical Journey*?” Students are assigned a group discussed in the film, and research their cultural practices. Afterwards, they make a claim as to what American tradition this culture helped shape and influence. Finally, students present their findings in a culture day.

FROM THE FILM:

America’s Musical Journey discusses many different groups who have shaped the evolution of music within American culture. However, they have shaped much more than music. This lesson investigates the different traditions that have enriched our national culture.



LESSON 7: CULTURAL PROJECT

MATERIALS:

- Music Cultural Influence handout*
- Research Culture Project handout*
- Speaker capable of playing songs for students
- Internet capable devices for each pair of students

TEACHER PREP:

DAY 1:

You will need to identify three modern songs to play for students. Be sure to listen to the songs beforehand to ensure that they are appropriate to be played in front of middle aged students. It is also helpful to print the lyrics for students to follow along as you play the song.

DAY 3:

On this day students will be presenting their findings to the class. This will mean that you need to prepare an easy way for students to pull up their presentations on the computer connected to the front screen. If you are opting to do the presentations as a “tradition day” you may want to consider moving this lesson back by a few school days so that students have time to gather and prepare the cultural tradition they will feature in the showcase.

TO DO:

BEFORE VIEWING THE FILM:

Prepare students to view the film, *America’s Musical Journey*. Ask students to name their favorite American traditions. Afterwards, remind students that the United States is a country of immigrants and descendants of immigrants. The cultures that people brought to America influenced the creation of our national traditions. The film *America’s Musical Journey* investigates the interaction between diverse people and the creation of music. Ask students to pay special attention to the different groups of people discussed in the film. Later, students will use this knowledge to conduct a project that investigates other ways that these cultures have shaped American traditions.

DAY 1:

1. Ask students to share what cultural groups they recall from viewing the film, *America’s Musical Journey*.
2. Inform students that they will be investigating ways that those cultural groups influenced the various types of music born in America.
3. Direct students to view the sheet *Music Cultural Influence*. On this sheet, there is a list of the different types of cultures and musical traditions that were mentioned in the film, *America’s Musical Journey*. Have students read over the descriptions and share with a partner memories they have of that group appearing in *America’s Musical Journey*.

LESSON 7: CULTURAL PROJECT



TO DO (DAY 1 CONTINUED):

4. Select five popular songs from today's music. Each song should be varied and have some sort of influence from one of the groups listed on the *Musical Cultural Influence* sheet (a suggested list is found below). Play each song for students and ask them to hypothesize which cultural group influenced that music and justify their claim from what they hear within the song.

Suggested Songs: *One Day*, Matisyahu; *Miami*, Will Smith; *Alejandro*, Lady Gaga; *Wavin' Flag*, K'Naan

5. As an extension, have students select one of their own favorite songs, and identify cultural music influences within the song and provide evidence that supports their claim.

DAY 2:

1. Inform students that over the next two days, they will research other ways that the cultural groups featured in *America's Musical Journey* influence our national traditions and cultures.

2. Divide students into groups of two to three. Assign each student pair a cultural group listed in the *Researching Culture Project* sheet. Have students research the different cultural aspects of that group. Afterwards, students should identify at least two different ways that the culture of this group influences current American traditions. Students should prepare to present their findings on the cultural group and the traditions that they influence to the class during the next lesson.

3. Before allowing students to research on their Internet capable devices, it may be important to review best practices for identifying valid sources and citing information.

4. At the end of the class, review with students elements of successful presentations and public speaking techniques (for example: create slides with limited text, use media images on slides, look at audience and not the screen while presenting, do not read directly from slides, and expand upon the limited text within the slide).

DAY 3:

1. Students should present their findings to the class as a whole. Students may choose how they want to present the information with digital platforms like Power Point, Google Slides, or any other online presentation software.

LESSON 7: CULTURAL PROJECT

EXTENSION ACTIVITIES:

Consider using this small project as an opportunity to reinforce research techniques and the elements of a strong argument.

See <https://www.hotelschool.co/5-things-to-remember-when-conducting-online-research/> for resources and tips on guiding student thinking.

As an extension, you may chose to do the presentations as a celebrated “tradition day” where students must create an interactive experience of the American tradition that is influenced by their cultural group. (This may include students paying music, having people dance, putting on the garb of the tradition, or participating in some sort of traditional meal).



Music Cultural Influence

Directions: Read the descriptions of the musical traditions that influence the music of the United States. Your teacher will play three modern songs. As you listen to each, identify at least one music tradition that you hear featured within each song. Name the influencing music tradition and use evidence from within the song to support your claim of its presence in the music.

Cuban Music:

- Quick Tempos
- Bass notes
- Scratcher instrument in percussion
- Lyrics often talk of love

Song 1:

Musical Influences I Hear:

Evidence for Claim:

European Music:

- Use of guitars
- Use of horns
- Lyrics often tell stories or related history

Song 2:

Musical Influences I Hear:

Evidence for Claim:

African Music:

- Heavy focus on drums
- Vocals are often sounds and not actual words.
- Dance is as important as the music itself

Song 3:

Musical Influences I Hear:

Evidence for Claim:

Research Culture Project

Directions: You and a partner will be assigned one of the cultural groups below. For that cultural group, research the different cultural aspects and traditions of that region. Afterwards, identify at least two American traditions that are influenced by this culture. Explain how the American tradition reflects aspects of the cultural group you are assigned.

Cuba

Panama

West Africa

England

Gaelic

Haiti

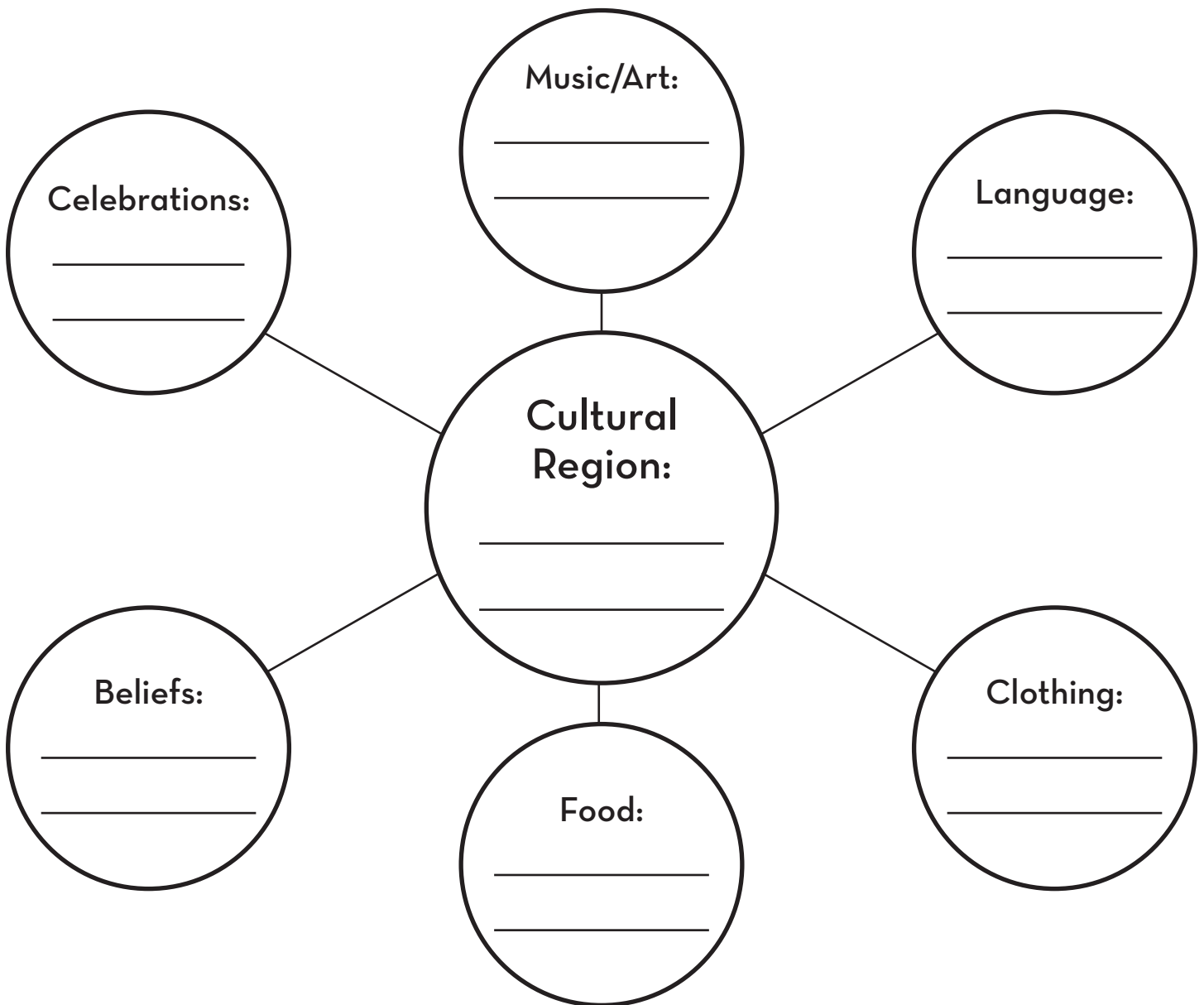

LESSON 8: LYRICAL TALES

GRADE LEVEL 6-8

(1) 15 MINUTE PREP LESSON

(2) 45 MINUTE LESSONS



GRADE LEVEL 6-7
(1) 15 MINUTE PREP LESSON
(2) 45 MINUTE LESSONS

LESSON 8: LYRICAL TALES

ELA STANDARDS:

- Cite several pieces of textual evidence to support analysis of what the text says explicitly as well as inferences drawn from the text.

SOCIAL STUDIES STANDARDS:

- Explain how culture unites and divides modern societies and regions (e.g. enslavement of various peoples, caste system, religious conflict and Social Darwinism).

LESSON OVERVIEW:

In this lesson, students read lyrics from songs passed from plantation to plantation during the period of the Underground Railroad. From the lyrics, they make inferences about the lives and values of the brave people involved in freeing enslaved peoples. Afterwards, students research lyrics from our modern era and make judgments of how they reinforce values and build cultural movements.

FROM THE FILM:

The film discusses the influence that enslaved humans had on the New Orleans musical tradition. Music, however, went far beyond the entertainment people would gather to hear in the city square. The music of American slaves was a way of transcending bondage, elevating values, and resisting oppression. Today, music still inspires us to dream big and build a better world.





LESSON 8: LYRICAL TALES

MATERIALS:

- Secret Messages from the Underground Railroad* handout
- Writing My Own Music for Change* handout

TEACHER PREP:

DAY 2:

On this day, you will open the class by playing a song of your choice and displaying the lyrics on the board. Before class, select the song, find a digital copy to play on the board, test the sound, and check the lyrics to ensure that they are appropriate to be played for students.

Create posters to be hung around the walls of your classroom. Students will write down ideas about social issues they are passionate about on each poster during a gallery walk. The posters should be blank except for a title. The six titles that should be included on the posters are:

- * *Issues I See At School*
- * *Issues I See At Home*
- * *Issues I See In My Neighborhood*
- * *Issues I See In Our Country*
- * *Issues I See In Our World*
- * *Issues I See In The Media*

Read about the meaning of Tubman's lyrics at

<http://www.harriet-tubman.org/songs-of-the-underground-railroad/>

TO DO:

BEFORE VIEWING THE FILM:

Prepare students to view the film, *America's Musical Journey*.

Ask students to share their favorite song with a partner. Afterwards, ask students if they could explain the meaning of the song. Are there any messages the song is trying to convey? Inform students that they are going to watch *America's Musical Journey*, a film that chronicles the evolution of culture and music in our society. Ask students to pay special attention to the songs that they hear being sung. Can they detect any meaning within the lyrics of the song?

DAY 1:

1. As a warm up, have students share songs they remember from the film.

2. Introduce the idea of music as more than entertainment. Music has been historically used as a means to convey messages, reinforce community values, and galvanize groups for action or change. For example, the British originally wrote the song "Yankee Doodle" to make fun of the colonists for their manners and way of dress. They used to play the song before battle as a way of taunting the rebels. The rebels, however, turned the song on its head and started to sing it as a badge of pride.

LESSON 8: LYRICAL TALES

TO DO (DAY 1 CONTINUED):

3. Enslaved peoples in the South sang as they worked. These songs not only uplifted each other, they also provided a way of spreading the message of resistance. Students will read lyrics written by Harriett Tubman for the Underground Railroad. These songs contained secret messages to help slaves escape their masters. Sometimes the songs provided directional information (north south east west), sometimes they gave information about geographic features to follow, and other times they hinted at when it was safe to escape the plantation. Students should read each song lyric and infer what the song was intended to tell enslaved peoples. Then, students should support their argument with two pieces of evidence within the lyrics.

DAY 2:

1. As a warm up, display the lyrics from a modern song of your own choosing that sends a message for social change (possible options are “One Day” by Matisyahu or “With My Own Two Hands” by Ben Harper). Ask students to use the skills they practiced in the first lesson to make an inference about what this song is encouraging people to do and support that with two pieces of evidence from the lyrics.

2. Tell students that they are going to create their own music or poetry that encourages people to make some kind of change. They will begin by brainstorming current issues where they would like to see change. Show students the locations of the six posters you placed around the room (see teacher preparation). Divide students into six groups and have them travel to each poster category. They should spend approximately three minutes at each poster writing down issues or problems that they would like to see changed or solved in each category.

3. Afterwards, have them return to their desks and hand out the *Writing My Own Music for Change* sheet. Have students first select one problem that they wrote or saw on the posters. They should then fill in the song planning sheet with the relevant details to that problem. If students are unfamiliar with concepts of stanzas and chorus structure in poetry and music, spend a minute identifying those elements in the song you played for students at the beginning of class.

4. Afterwards, help students create a poem or song that addresses the issue and motivates people to do something differently.

5. Have students share their songs with the class and explain its hidden meaning.



LESSON 8: LYRICAL TALES

EXTENSION ACTIVITIES:

Visit the Recording Academy's Grammy Museum website: grammymuseum.org. Under the Education section, they have pre-written curriculum that can take students even deeper into the concept of music as a social change agent throughout history and into today.

Have students select a song that they hear played on the radio. Have students identify the stanzas and chorus of the song. Afterwards, they should conduct a small research investigation into the person or group who wrote the song. What is their personal history? After learning about the person or group, they should try to infer what kind of message they were trying to send with the lyrics of the song. How does it reveal any ideas that person or group might be passionate about?



Secret Messages from the Underground Railroad

Directions: Harriet Tubman wrote many songs for the underground railroad. She would secretly teach slaves the songs to sing while working on plantations. Each song carried a secret message that was supposed to help slaves escape their masters and run for freedom. The messages gave information about where to hide, when to escape, and how to navigate the land to the North. Read the lyrics to each song. After, infer, what was the song secretly telling enslaved people to do to escape? Underline two pieces of evidence in the lyrics and explain how that supports your position. Use evidence from the song to support your claim.

“Wade In the Water”

Chorus: Wade in the Water, wade in the water children.

Wade in the Water. God’s gonna trouble the water.
Who are those children all dressed in Red?
God’s gonna trouble the water.
Must be the ones that Moses led.
God’s gonna trouble the water.

Chorus

Who are those children all dressed in White?
God’s gonna trouble the water.
Must be the ones of the Israelites.
God’s gonna trouble the water.

Chorus

Who are those children all dressed in Blue?
God’s gonna trouble the water.
Must be the ones that made it through.
God’s gonna trouble the water.

Chorus

What message do you infer Harriet is trying to communicate to slaves?

Underline two pieces of evidence and explain how they support your theory:

Secret Messages from the Underground Railroad

“Steal Away”

Chorus: Steal away, steal away!

Steal away to Jesus?

Steal away, steal away home!

I ain't got long to stay here!

My Lord calls me!

He calls me by the thunder!

The trumpet sound it in my soul!

I ain't got long to stay here!

Chorus

My Lord calls me!

He calls me by the lightning!

The trumpet sound it in my soul!

I ain't got long to stay here!

Chorus

What message do you infer Harriet is trying to communicate to slaves?

Underline two pieces of evidence and explain how they support your theory:

Secret Messages from the Underground Railroad

“Follow the Drinking Gourd”

When the Sun comes back
And the first quail calls
Follow the Drinking Gourd.
For the old man is a-waiting for to carry you
to freedom
If you follow the Drinking Gourd.

The riverbank makes a very good road.
The dead trees will show you the way.
Left foot, peg foot, traveling on,
Follow the Drinking Gourd.

The river ends between two hills
Follow the Drinking Gourd.
There's another river on the other side
Follow the Drinking Gourd.

When the great big river meets the little river
Follow the Drinking Gourd.
For the old man is a-waiting for to carry you
to freedom
If you follow the Drinking Gourd.

What message do you infer Harriet is trying to communicate to slaves?

Underline two pieces of evidence and explain how they support your theory:

Writing My Own Music for Change

Directions: During this activity, you will write your own song that will send a message of change. First, you will brainstorm different topics with your class. Afterwards, you will chose a topic you are most passionate about. Then you will plan a song or poem that would encourage people to make the change you feel passionately about.

Part 1: Chose your topic

I am passion about _____ .

In the future, I would like to see this change by _____ .

Part 2: Plan the chorus to your poem or lyric.

The chorus is the part of a song that is repeated several times. The chorus should be the most memorable part of the song. You should plan your chorus to send the heart of the message of what you want to change about the world. Brainstorm ideas for the chorus below:

Part 3: Plan the stanzas.

The stanzas are the part of the song that give more detail about the issue you want to communicate. Brainstorm details about the issue you selected or the change you are encouraging people to make below:

Writing My Own Music for Change

Part 4: Write a song!

Don't worry about the song lyrics being perfect or rhyming. Focus on conveying the message you are trying to send people. The song should contain two stanza sections and a chorus that is repeated at least twice.

SCIENCE
EXTENSION LESSON:
**STRING
TELEPHONE**

GRADE LEVEL K-2
(1) 45 MINUTE LESSON



GRADE LEVEL K-2 (1) 45 MINUTE LESSON

NGSS STANDARDS:

- Use tools and materials to design and build a device that uses light or sound to solve the problem of communicating over a distance.

MATH STANDARDS:

- Order three objects by length; compare the lengths of two objects indirectly by using a third object.
- Express the length of an object as a whole number of length units, by laying multiple copies of a shorter object (the length unit) end to end; understand that the length measurement of an object is the number of same-size length units that span it with no gaps or overlaps.

SCIENCE EXTENSION LESSON: STRING TELEPHONE

LESSON OVERVIEW:

In this lesson, students will investigate how music and sound waves move through material by constructing a string telephone. Students will use the scientific process to determine the best material to construct a device capable of transmitting music sound waves over a certain distance.

FROM THE FILM:

America's Musical Journey tells the story of diverse people coming together to create new forms of art. As people moved across the world, they made new friends and shared their songs and music. In this lesson, we help two students who moved next door to each other to sing and share songs at night by constructing string telephones.



SCIENCE EXTENSION LESSON: STRING TELEPHONE

MATERIALS:

- Making a Better Cup Phone*
- Paper Cups
- Twine
- Measuring Blocks or Rulers
- Optional: Styrofoam Cups

TEACHER PREP:

Prepare materials bags for each pair of students. The bag should contain 2 paper cups with a hole punched in the bottom. Three different strings cut into lengths 3 feet, 6 feet, and 9 feet. (Optional to include cups of different kinds of materials).

TO DO:

1. Remind students that *America's Musical Journey* tells the story of people moving across the country and the world to meet in a new place, make new friends, and create new sounds. Ask if the students can raise their hands and share a time when they moved and had to make new friends.
2. Tell students that moving can be a lot of fun, but sometimes, it can be hard to make friends when you first arrive. Sometimes, when new people come in to a community, other people don't understand their culture. It can be hard to fit in. At first, when Louis Armstrong moved to the North, he was not allowed to share the same room with people of a different skin color.
3. Imagine a new family moves in next door to a student in your class. The two immediately become friends and share a love for music. They spend recess drumming on different materials to see the sound it makes. However, when they go home at night, their parents won't let them go over to each other's house to play. Can we help create a way for the two to talk and make music even when in different homes?
4. Introduce students to the nature of sound traveling in waves. When one person sings, it creates sound waves. The waves have to travel through a medium to get to the other person's ear for them to hear the song. That medium is usually air.
5. As a demonstration, have two students sit one foot apart from each other. Have one student whisper "hello how are you" to the other. Have the student give a thumbs up if they are able to hear it. Then, have the students separate by six feet (show students how to measure six feet with a ruler or block pieces of paper). Once again, have the student whisper "hello how are you" (be sure to remind them to do so at the same volume). Ask the student if they were able to hear the message as easily. Once again, have the students separate by six feet and repeat the procedure. Note that the farther away people are from each other, the harder it is for the sound waves to reach their ear. Sound must travel through the air to get from one person's mouth to your ear. Sound waves struggle to move through air. We must try to make a device that sound travels through better. The device can help the two friends sing to each other at night.

SCIENCE EXTENSION LESSON: STRING TELEPHONE



TO DO (CONTINUED):

6. Introduce students to the concept of a cup telephone connected by a string. Model how it works by speaking into one end and holding the other far away from you with the string tight. The sound waves find it easier to travel through a solid medium than the air. The waves move through the cup, then down the string, and into the cup on the other end.
7. Tell students that they will investigate the best way to build a string telephone for the two students to use to talk to each other from their windows at night.
8. Give each pair of students a materials bag (please see teacher prep). Instruct them to first pull out the three strings and organize them from shortest to longest. (If appropriate for your grade level, you can also have them measure the actual length of each).
9. Demonstrate how to string the ends of the string through the cups and knot them to prevent them slipping out. Ask students to first set up the telephone using the short string and practice talking to each other. Afterwards, have them rate how well they were able to talk on a scale of 1-5 stars.
10. Next, have them repeat the procedure for the medium and long strings, each time attempting to talk to each other and rating how well they heard on a scale of 1-5 stars.
11. Debrief as a class what they learned about sound's ability to travel through solid material.

EXTENSION ACTIVITIES:

Have students repeat the experiment with paper cups instead of Styrofoam and draw further conclusions about what kind of material is the best at transmitting sound.

Making a Better Cup Phone

Directions:

- 1) Organize the string from shortest to longest.
- 2) Tie the string to the cups. Follow your teacher's directions.
- 3) Each partner takes one cup.
- 4) Stand apart from your partner. Keep the string tight between you.
- 5) One partner talks into the cup. The other partner holds the cup to their ear.
- 6) Record, how many stars would you give each string telephone length.

Short:

Rate the Sound:



Medium:

Rate the Sound:



Long:

Rate the Sound:



SCIENCE
EXTENSION LESSON:
**ENCODING
SOUND**

GRADE LEVEL 3-5
(1) 45 MINUTE LESSON



GRADE LEVEL 3-5
(1) 45 MINUTE LESSON

SCIENCE EXTENSION LESSON: ENCODING SOUND

NGSS STANDARDS:

- Use tools and materials to design and build a device that uses light or sound to solve the problem of communicating over a distance.

MATH STANDARDS:

- Order three objects by length; compare the lengths of two objects indirectly by using a third object.
- Express the length of an object as a whole number of length units, by laying multiple copies of a shorter object (the length unit) end to end; understand that the length measurement of an object is the number of same-size length units that span it with no gaps or overlaps.

LESSON OVERVIEW:

In this lesson, students will create a drum using a balloon and jar. Afterwards, they learn about the history of using sound and beats to communicate across long distances. Students practice tapping out messages to each other with their drums using Morse Code.

FROM THE FILM:

America's Musical Journey features many different genres of music that were birthed in the United States. Jazz, Hip Hop, and Salsa all have their distinct sounds. But beneath those sounds beats the rhythm of percussion instruments. Stripped down to their basics, musical genres can still be identified by the patterns found within their percussion instruments. In this lesson, students learn about ways that sound patterns have been used in society.



SCIENCE EXTENSION LESSON: ENCODING SOUND

MATERIALS:

Each student will need a balloon, rubber band, and glass jar.

- Pencil or Pen

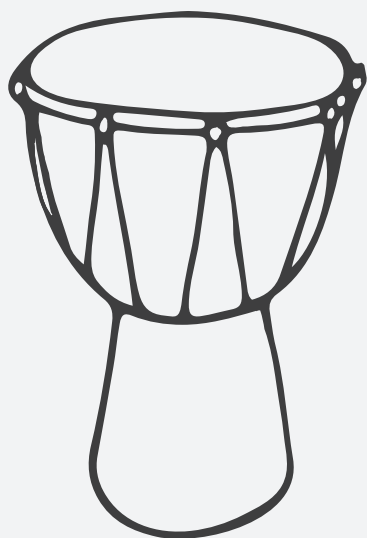

TEACHER PREP:

In order to collect the necessary amount of glass jars, it is recommended that you send home a request to parents a couple weeks in advance.

Any type of jar made of glass will be suitable (baby food, spaghetti sauce, olives, pickles, etc). During this lesson, students will use the drums they create to beat out Morse code. Before you begin the lesson, you should source an image or worksheet displaying the symbols. You can print this sheet out for each student or prepare it to be displayed on your front of room screen.

TO DO:

1. Remind students that drum circles were the center of social life in New Orleans. Free and non-free people would gather in the square to create rhythm and dance. Historically, drums and rhythm have been used for much more than just dance. During today's lesson, you will create drums, then use them to send secret messages to each other.
2. First, students will begin by assembling the drums. Demonstrate how to do this for the class before allowing the students to attempt themselves. Cut off the bottom inch of a deflated balloon. Stretch out the balloon with your fingers and place it over the mouth of a Ball jar so that the surface is tight (there may be a small dimple on the top, this is okay). Use the rubber band to wrap around the jar and secure the balloon.
3. Show students how to use a pencil or pen to tap sounds on the drum.
4. Inform students that we have been using drums to send out messages across long distances for thousands of years. Soldiers during the Roman era used to beat out different drum patterns to send messages to fighters across the field. Patterns of slow beats let soldiers know to walk slowly along the field. Demonstrate beating out a slow pattern and invite the students to beat in sync with you. Patterns of fast beats let soldiers know it was time to run and charge. Demonstrate beating out a fast pattern and invite students to join you.
5. Show an image of Morse code on the board or print out pages for each student to use as reference. Patterns of drum beats eventually developed into Morse code. Morse code is a language of long and slow beats that act as code for different letters of the alphabet. Short beats are represented on paper as dots. Long beats are represented by dashes. Each letter is made of up beats. For example, the letter A is typed using * - (short beat then long beat). Draw the letter A on the board, and the dot dash symbol beneath it. Have students practice with you. Demonstrate for the class how to beat out an A and have them follow along.
6. A famous signal still sent out by boats when they are in trouble is SOS, Save Our Ship. The S is coded by 3 short beats, or dots. The O is coded by 3 long beats or dashes. Demonstrate the pattern for the students and invite them to practice.

SCIENCE EXTENSION LESSON: ENCODING SOUND

H • • • •

E •

L • — • •

L • — • •

O — — —

TO DO (CONTINUED):

7. Ask students to write down the dot and dash pattern they would use to write out HELLO. Then attempt to drum it on the drum.

8. Now, have students create a secret message for their partner. The message must be just two words. In a place that their partner can not see, have them write out the two words, then write the Morse code beneath it. Once students think they have their message, have them beat it out on the drum for their partner. Their partner should record the beats then attempt to decode their message.

EXTENSION ACTIVITIES:

You can turn this lesson into an engineering challenge by providing students with multiple different types of “drum covers” other than balloons. Have students stretch different materials like felt, cloth, aluminum foil, or leather over the top of the jar, secure it with a balloon, and test out the sounds it makes. (The original jar cover often works well too!) Have students select what they believe to be the best material to make the drum cover.



ADDITIONAL RESOURCES:

COUNTRY MUSIC HALL OF FAME:

<https://countrymusichalloffame.org/>

This site provides many excellent distance learning lessons for teachers to use in the classroom. Lessons include activities around lyric writing and the history of country music.

ROCK & ROLL HALL OF FAME:

<https://www.rockhall.com/>

This museum hosts a plethora of primary documents on the history of rock and roll. Supported by Case Western University, the online collection of documents include collections on the history of the Chicago music industry and the country music of Johnny Cash.

THE SCIENCE OF MUSIC HOSTED BY THE EXPLORATORIUM:

<http://www.exploratorium.edu/music/>

This online museum exhibit engages students in investigations and movies around the science of music.

SMITHSONIAN FOLKWAYS:

<https://folkways.si.edu/>

The Smithsonian Folkways contains multiple lesson plans tied to global music genres, including early American roots music.

TEACHING TOLERANCE:

<https://www.tolerance.org/>

Teaching tolerance is an online community of expert educators offering lessons and best practices in engaging students in challenging discussions. This resource provides ample advice and lesson plans on how to discuss racially charged subjects like slavery and the Great Migration.

MAKEY MAKEY:

<http://makeymakey.com/>

Makey Makey is an invention kit for the 21st century that turns everyday objects into touchpads and combine them with the internet to create music. This device and its professional development help teachers connect music to the computer science and circuits.

GRAMMY MUSEUM:

<http://www.grammymuseum.org/education>

The Grammy Museum contains a wealth of knowledge and lessons for educators of all types. The website hosts regular teacher webinars that cover topics on using music to teach content in the classroom. The site also contains downloadable curriculum for teachers use in the classroom.



WRITERS AND CONTRIBUTORS:

WRITERS:

ANDREA ANN ANDERSON, MA Science Education,
Discovery Place, Inc.

BETHANY GREGORY, MA History,
Cabarrus County School District.

LESSON PLAN DEVELOPERS:

ANDREA ANN ANDERSON, MA Science Education,
Discovery Place, Inc.

LESSON PLAN REVIEWERS:

BETHANY GREGORY, MA History,
Cabarrus County School District.

PROJECT MANAGEMENT:

JOANIE PHILIPP, Discovery Place, Inc.

LORI RICK, MacGillivray Freeman Films

GRAPHIC DESIGN:

ALTHEA HOLENKO, Discovery Place, Inc.

ANDREW CREWS, Discovery Place, Inc.

America's Musical Journey is a MacGillivray Freeman film produced in association with Brand USA and presented globally by Expedia, Inc.

America's Musical Journey Educator Guide © 2017 VisitTheUSA.com.
Individual artworks and photographs are copyright their respective creators.
All rights reserved. IMAX® is a registered trademark of IMAX Corporation.
Academy Award® is a registered trademark of the Academy of Motion Picture Arts and Sciences.

Note: This publication may be reproduced for classroom use only. This publication may not be reproduced for storage in a retrieval system, or transmitted, in any form by any means—electronic, mechanical, recording—without prior permission



MacGillivray Freeman's

A **AMERICA'S**
MUSICAL
JOURNEY

A story of culture, creativity and the music that shaped America.